

GT Series
Operator's Manual



PROPRIETARY STATEMENT

Thermo GasTech owns proprietary rights in the information disclosed within. By receiving this document, the recipient agrees that neither this document nor the information disclosed within nor any part shall be reproduced or transferred to other documents or used or disclosed to others for manufacturing or for any other purpose except as specifically authorized in writing by **Thermo** GasTech.

COPYRIGHT STATEMENT

Information contained in this document is protected by copyright. No part of this document may be photocopied, reproduced, or translated to another program or system without prior written authorization from **Thermo** GasTech., © 2001, **Thermo** GasTech.

TRADEMARK STATEMENT

Protected through use and/or registration in the United States and many foreign countries are the trademarks and service marks of **Thermo** GasTech. The use of the ® symbol indicates registration in the United States only; registrations may not have been issued at present in other countries. All other product names and logos are trademarks of their respective owners.

GASTECH® is a trademark of **Thermo** GasTech and is registered with the U.S. Patent and Trademark Office.

DISCLAIMER

Under no circumstances will **Thermo** GasTech be liable for any claims, losses, or damages resulting from or arising out of the repair or modification of the equipment by a party other than **Thermo** GasTech or its authorized service representatives, or by operation or use of the equipment other than in accordance with the printed instructions provided by **Thermo** GasTech or if the equipment has been improperly maintained or subject to neglect or accident. Any of the foregoing will void the warranty.

EXPORT STATEMENT

Export of the information and products in this manual from the U.S.A., or re-export from another country, may require written authorization from the U.S. Department of Commerce. Printed in the U.S.A.

REVISIONS TO MANUAL

All information contained in this manual is believed to be true and correct at the time of printing. However, as part of its continuing efforts to improve its products and their documentation, **Thermo** GasTech reserves the right to make changes at any time without notice. Any revised copies of this manual can be obtained by writing **Thermo** GasTech.



WARNING



THIS INSTRUMENT IS DESIGNED TO DETECT ONE OR MORE OF THE FOLLOWING:

FLAMMABLE VAPORS, OXYGEN CONTENT, AND/OR TOXIC GAS AND TO GIVE WARNING BEFORE THEY REACH HARMFUL CONDITIONS. IN ORDER TO ENSURE THAT IT WILL WARN OF DANGEROUS CONCENTRATIONS, IT IS ESSENTIAL THAT THE INSTRUCTIONS IN THIS MANUAL, PARTICULARLY THOSE CONCERNING START UP, OPERATION, CALIBRATION, AND MAINTENANCE, BE READ, UNDERSTOOD, AND FOLLOWED.

NOTATION CONVENTIONS

Notices are used in this operator's manual to alert you to hazardous conditions to person or instrument and to notify you of additional information. This operator's manual uses the following notices.



WARNING

Notifies you of potential danger that can result in personal injury or death.



CAUTION

Notifies you of potential damage to equipment.



NOTE

Notifies you of additional or critical information.



SERVICE POLICY

Thermo GasTech maintains an instrument service facility at the factory as well as authorized service facilities around the world. Should your instrument require service, you may contact us toll free at **1-877-GASTECH (427-8324)** for **US only** or **1-510-745-8700**, or visit our website www.thermogastech.com for authorized service locations.

For warranty or non-warranty repairs, call us to complete a Return Material Authorization (RMA) form, obtain billing and shipping information and tell us the nature of the problem. For non-warranty repairs, you will need to provide a purchase order number. If you need to set a limit to the repairs costs, state a “Not to Exceed” figure. If you need a quotation before you can authorized the repair costs, so state, but understand this will incur additional costs and may delay processing of the repair.

You may send the unit, prepaid, to: **Thermo GasTech, 8407 Central Ave., Newark, CA 94560-3431, Attn.: Service Department.** Enclose the copy of the RMA (Return Material Authorization) that was previously faxed to you. Pack the instrument and all its accessories (preferably in its original packing) and any special instructions.

Repairs are warranted for 90 days from the date of shipment. Sensors have individual warranties.



NOTE

Thermo GasTech assumes no liability for work performed by unauthorized service facilities.

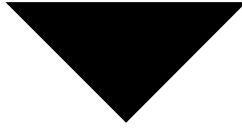

WARRANTY STATEMENT

Thermo GasTech (the “Company”) warrants that the Products will operate substantially in conformance with the Company’s published specifications, when subjected to normal, proper, and intended usage by properly trained personnel, for a period of one (1) year after shipment to Customer (the “Warranty Period”). The Company agrees during the Warranty Period, provided it is promptly notified in writing upon the discovery of any defect and further provided that all costs of returning the defective Products to the Company are prepaid by Customer, to repair or replace, at the Company’s option, defective products so as to cause the same to operate in substantial conformance with said specifications. Replacement parts may be new or refurbished, at the election of the Company. All replaced parts shall become the property of the Company.

Lamps, pump diaphragms/valves, batteries, fuses, bulbs, and other expendable items are expressly excluded from the warranty.

The Company’s sole liability with respect to equipment, materials, parts, or software furnished to the Company by third party suppliers shall be limited to the assignment by the Company to Customer of any such third-party supplier’s warranty, to the extent the same is assignable. In no event shall the Company have any obligation to make repairs, replacements, or corrections required, in whole or in part, as the result of (i) normal wear and tear, (ii) accident, disaster, or event of force majeure, (iii) misuse, fault, or negligence of or by Customer, (iv) use of the Products in a manner for which they were not designed, (v) causes external to the Products such as, but not limited to, power failure or electrical power surges, or (vi) use of the Products in combination with equipment or software not supplied by the Company.

ANY INSTALLATION, MAINTENANCE, REPAIR, SERVICE, RELOCATION, OR ALTERATION TO OR OF, OR OTHER TAMPERING WITH, THE PRODUCTS PERFORMED BY ANY PERSON OR ENTITY OTHER THAN THE COMPANY WITHOUT THE COMPANY’S PRIOR WRITTEN APPROVAL, OR ANY USE OF REPLACEMENT PARTS NOT SUPPLIED BY THE COMPANY, SHALL IMMEDIATELY VOID AND CANCEL ALL WARRANTIES WITH RESPECT TO THE AFFECTED PRODUCTS.

THE OBLIGATION TO REPAIR OR REPLACE A DEFECTIVE PRODUCT SHALL BE THE SOLE REMEDY OF CUSTOMER IN THE EVENT OF A DEFECTIVE PRODUCT. EXCEPT AS EXPRESSLY PROVIDED IN THIS SECTION, THE COMPANY DISCLAIMS ALL WARRANTIES, WHETHER EXPRESS OR IMPLIED, ORAL OR WRITTEN, WITH RESPECT TO THE PRODUCTS, INCLUDING WITHOUT LIMITATION ALL IMPLIED WARRANTIES OF MERCHANTABILITY OR FITNESS FOR ANY PARTICULAR PURPOSE. THE COMPANY DOES NOT WARRANT THAT THE PRODUCTS ARE ERROR-FREE OR WILL ACCOMPLISH ANY PARTICULAR RESULT.

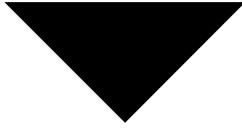



TABLE OF CONTENTS

Chapter 1

Introduction	
About the GT Series	1
Specifications	3
Sensor Specifications	5
Optional Accessories	6

Chapter 2

Description	
External Description	7
Internal Description	9

Chapter 3

Start Up	
Preparing for Start Up	11
Starting Up the GT	12
Shutting Off the GT	14

Chapter 4

Operation	
Normal Operation	15
Operator Indications	17

Chapter 5

Calibration	
Preparing the Calibration Kit	23
Calibrating the GT	24

Chapter 6

Maintenance	
Preventive Maintenance	27
Troubleshooting	29
Recharging Ni-Cd Batteries	32
Replacing Components	33

Appendix A

Parts List	39
------------------	----

Appendix B

GT Configuration	
The Instrument Set-Up Program	43
The Channel Set-Up Program	47
The Function Program	52

Appendix C

Interference Factors	
Filament Poisoning	59
High Concentration of Combustible Gas	59
Oxygen-Deficient Mixtures	60
Oxygen-Rich Mixtures	60
Interfering Gases	60
Relative Combustible Response	61

Appendix D

Supplemental Instructions	
GT Land Surveyor	63
GT Transformer Gas Tester	66

INTRODUCTION

About the GT Series

The GT Series (shown in Figure 1-1) is a line of portable gas monitors capable of detecting from one to four gases. The GT displays up to four current gas levels simultaneously.

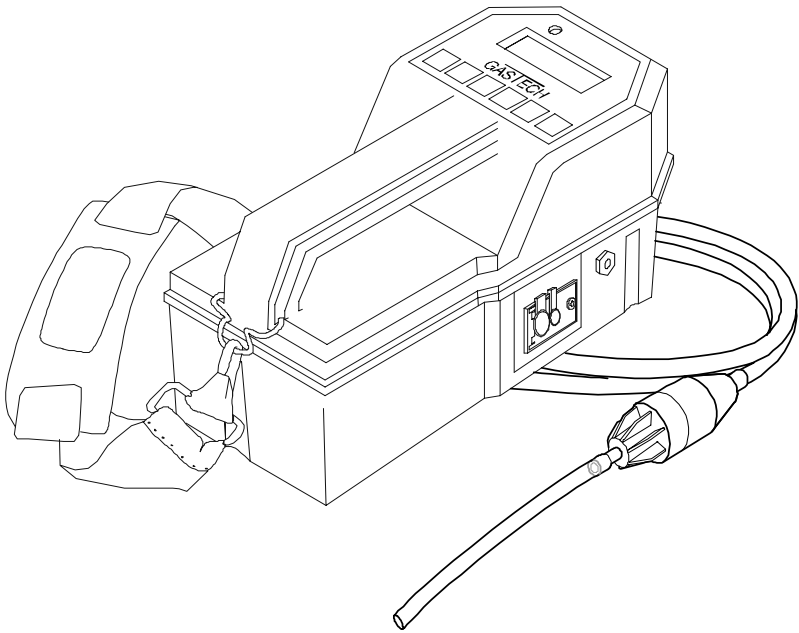

Figure 1-1 GT Series Gas Monitor

The GT Series can monitor an environment for hydrocarbons (LEL/ppm), oxygen (O_2), and up to two toxic gases, including carbon monoxide (CO), hydrogen sulfide (H_2S), ammonia (NH_3), chlorine (Cl_2), and sulfur dioxide (SO_2). The monitor detects gas by a sample-drawing method, and it utilizes up to four internal sensors that plug into assigned molded flow block receptacles



NOTE

Some combinations of toxic gases (e.g., H₂S and Cl₂) are not compatible. Consult factory for available combinations.

During operation, the GT alerts you with visual and audible alarms whenever a monitored gas reaches the preset alarm level.

The GT has an internal pump that continually draws the atmosphere sample into the external probe and hose, then into the monitor to the sensor(s).

The GT is powered by four “D” size alkaline or nickel-cadmium (Ni-Cd) batteries. A jack is provided on the GT so you can connect the external Ni-Cd battery charger.

Specifications

Table 1-1 lists specifications for the GT Series gas monitor.

Table 1-1 Specifications for the GT Series Gas Monitor

Intrinsic Safety Rating	Class I, Division 1, Groups A, B, C, and D
Sampling Method	Sample-drawing
Response Time	Initial: 5 seconds average (with 5-foot hose) 90% complete within 30 seconds (except NH ₃) 90% complete within 150 seconds (NH ₃)
Operating Temperature	-4° F to 113° F (-20° C to 45° C)
Humidity	0 to 95% relative humidity (RH), non-condensing
Regulatory Approvals	UL Classified; CSA Certified
Alarms	Audible/visible, coded for gas and trouble. Also a comfort beep that can be turned off.
Alarm Actions	Pump off; low battery; rising gas reading (rising or falling gas readings for oxygen); rising TWA and STEL reading (toxic versions only); sensor failure.
Alarm Functions	Alarm levels are user-selectable in the Channel Setup program (see Appendix. B, GT Configuration).
Display	Digital liquid crystal display (LCD). Displays up to four different gases at a time. A back light is available on demand.
Power Source	Four “D” size alkaline or Ni-Cd batteries.
Battery life	10 hours @ 68° F(20° C) Due to the nature of alkaline cells, battery life is greatly reduced at low temperatures and may be less than two hours at -15° C. Ni-Cd batteries are recommended for low temperature applications.
Controls	ON/OFF (power) button, RESET button, FUNC./+ display option button, BACK LITE/- display option button, ADJUST/ENTER button, and LEL/PPM readout button.
Dimensions	10 in. L x 5 in. W x 6 in. H (254 mm L x 152 mm W x 127 mm H)

Table 1-1 Specifications for the GT Series Gas Monitor

Weight	5 pounds (2.25 kg)
Case	High-impact, chemical resistant polycarbonate-polyester plastic with RF-resistant coating.
Standard Accessories ^{1,2}	Shoulder strap; hose; probe (with filter); 1/8" hex wrench; operator's manual; and quick reference card.

¹ A dedicated sample hose with float-probe is a standard accessory for the GT 202 only.

² GT models for transformer testing include the following standard accessories: dilution fitting, and gas collection bag.

Sensor Specifications

Table 1-2 lists specifications for the sensors that are available for GT Series gas monitors.

Table 1-2 Sensor Specifications for the GT Series gas monitors

Sensor	Sensor Type	Detection Range	Warn Setting	Alarm Setting	TWA Setting	STEL Setting	Accuracy (of display)	Repeatability (of display)
LEL/ppm	Catalytic compensated	0 to 100% LEL	10% LEL	50% LEL	N/A	N/A	± 5%	± 2%
LEL/ppm	Catalytic compensated	0 to 10,000 ppm	1000 ppm	5000 ppm	N/A	N/A	± 10%	± 5%
LEL/ppm ¹	Catalytic compensated	0 to 5,000 ppm	100 ppm	500 ppm	N/A	N/A	± 10%	± 5%
O ₂	Electrochemical	0 to 30.0% O ₂	23.5% O ₂	19.5% O ₂	N/A	N/A	± 0.5% by vol	± 0.2% by vol
H ₂ S	Electrochemical	0 to 200 ppm	10 ppm	15 ppm	10 ppm	15 ppm	± 10%	± 5%
CO	Electrochemical	0 to 300 ppm	25 ppm	200 ppm	25 ppm	200 ppm	± 10%	± 5%
SO ₂	Electrochemical	0 to 10.0 ppm	2.0 ppm	5.0 ppm	2.0 ppm	5.0 ppm	± 10%	± 5%
NH ₃	Electrochemical	0 to 100 ppm	25 ppm	35 ppm	25 ppm	35 ppm	± 20%	± 20%
Cl ₂	Electrochemical	0 to 10.0 ppm	0.5 ppm	1.0 ppm	0.5 ppm	1.0 ppm	± 10%	± 5%

¹ Optional range setting.

Optional Accessories

Table 1-3 lists the optional accessories available for the GT Series gas monitor. Part numbers for all accessories are in Appendix A, Parts Lists.

Table 1-3 GT Series Optional Accessories

Accessory	Description
Ni-Cd battery charger	Charges Ni-Cd batteries while still in the monitor. Provides a full charge over an 8-hour period, then drops to a sustaining rate. Includes an alkaline recognition feature that prevents you from attempting to recharge alkaline batteries.
Optional hoses and probes	Lengths of hose up to 100 feet are available (except Cl ₂ versions). Two optional 30-inch probes (aluminum with dust filter or fiberglass with hydrophobic filter) are available.
Dilution fitting	Used to provide sufficient oxygen to allow proper response of the hydrocarbon (LEL/ppm) sensor when sampling inert environments.
Moisture trap	Glass-bodied with a pleated paper filter that collects excess water that is drawn into or condensed in the sample hose.
Auxiliary hydrophobic filter	A filter with a water-impervious membrane that connects between the sampling hose and the GT's inlet fitting.
Remote Buzzer	Repeats all audible alarms of the GT. Plugs into the remote alarm jack (CHGR). Includes clip to attach to lapel or other convenient place.
Carrying case	A case that holds the GT and the most commonly used accessories. The case also has space to hold the Ni-Cd battery charger.
Confined space kit	This carrying case can contain all equipment and the most commonly used accessories necessary to safely and accurately calibrate and use the GT.
Calibration kit	A kit consisting of a carrying case containing gas cylinders, valves, and appropriate fittings to calibrate the GT.
Data retrieval kit	Windows 95/98/NT compatible software necessary to access the data stored in the GT. Includes mating hardware.

DESCRIPTION

External Description

All components located or typically accessed on the exterior of the GT Series gas monitor during operation.

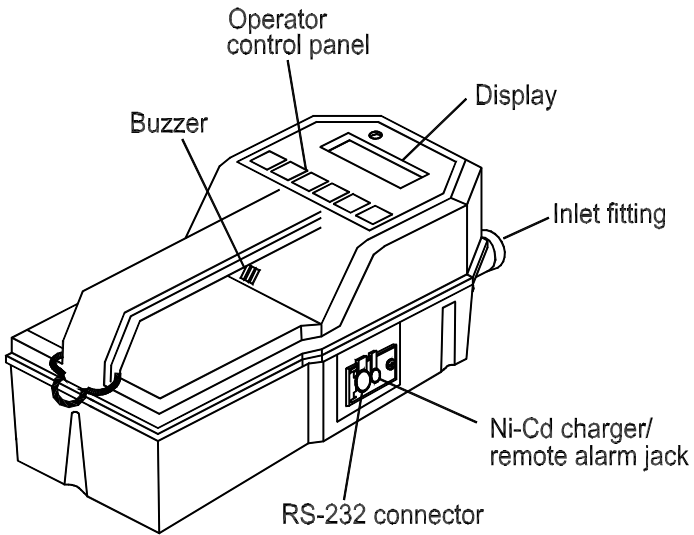

Figure 2-1 Exterior of the GT Series Gas Monitor

Operator Control Panel

The Operator Control Panel is on the top of the monitor. The panel consists of six embossed control buttons. The functions of each button are described below. Specific uses of the buttons during calibration and operation of your monitor are explained where appropriate.

ON/OFF



ON/OFF is a push-button that turns the monitor on or off when you press it.

- Press the button to turn the monitor on.
- Press and hold the button for at least five seconds to turn the monitor off.

RESET



RESET button:

- resets latching alarms
- restarts the pump if it shuts down due to a low flow condition
- exits or goes to previous screens in the Instrument Setup and Channel Setup programs.

FUNC./+



FUNC./+ button:

- scrolls through various options or set-up parameters
- increases the setting during calibration
- acts as a "YES" button during some tasks

BACK LITE/-



BACK LITE/- button:

- illuminates the display for 60 seconds
- decreases the setting during calibration
- acts as a "NO" button during some tasks

ADJUST/ENTER



ADJUST/ENTER button:

- adjusts the monitor to "fresh air" readings
- accepts calibration or other set-up parameters

LEL/PPM



LEL/PPM button:

- switches between LEL and hydrocarbon ppm ranges on models that have the combustible gas sensor.

On models that do not include the LEL/ppm sensor, this button is present but is not active.

Internal Description

To open the GT, first turn it over to gain access to the three captive screws. Use a flat blade screwdriver to disengage the screws from the upper half only. Turn the GT upright, then slowly separate the two halves. A neoprene gasket is situated in the upper half. This gasket is used to seal the perimeter of the monitor to prevent entry of dust or water.

If you need to completely separate the halves, disconnect the flat ribbon cable that runs between the large main board and the interconnect board, at the J4 connector on the interconnect board. The interconnect board is located directly behind the sensor(s).

Figure 2-2 shows the internal components of both halves of the GT.

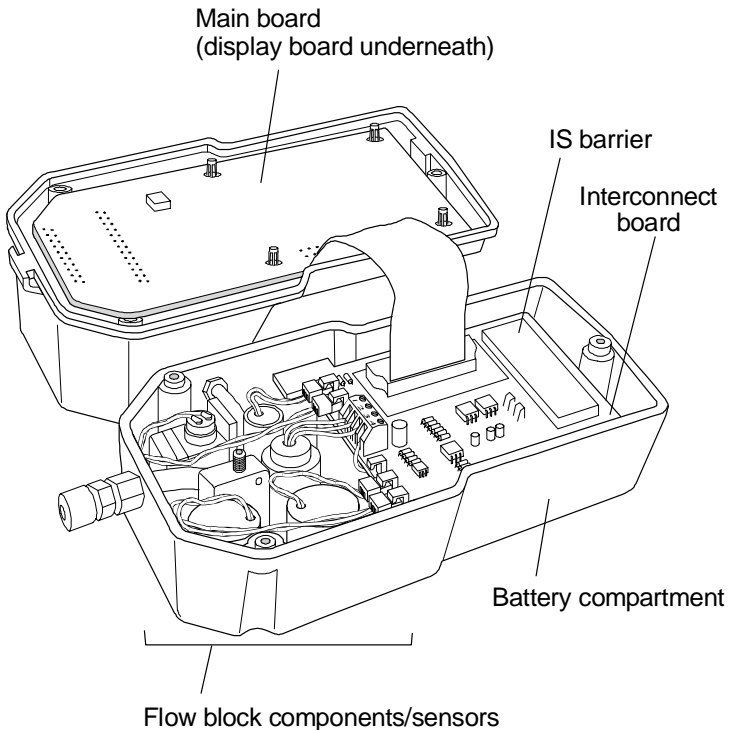

Figure 2-2 Interior of the GT Series Gas Monitor

START UP

Preparing for Start Up

1. Place the GT Series gas monitor upside down, use the 1/8" hex wrench (provided) to turn the large screw counterclockwise until it is loose in its socket, then pull up on it, and remove the battery compartment cover.
2. Install four "D" size batteries according to the diagram in the bottom of the battery compartment. Make sure that the battery polarities are correctly oriented.



NOTE

Make sure the slide switch at the bottom of the battery compartment is set to "**ALK**" for **alkaline batteries** or "**NI-CAD**" for **Ni-Cd batteries** (see Figure 6-3, GT Gas Monitor Battery Compartment).

3. Replace the battery compartment cover, then use the 1/8" hex wrench to turn the screw clockwise. Tighten snugly to compress gasket and seal battery compartment.



CAUTION

The toxic gas sensors require up to 15 minutes to stabilize, and the ammonia (NH₃) sensor requires up to 72 hours to stabilize after you install the batteries.

If your GT includes a toxic gas or ammonia sensor(s), do not turn on and use the GT during this period because the applicable reading(s) will be unstable.

4. Verify that the hydrophobic filter and cotton ball are in good condition and installed in the probe body.



NOTE

Transformer testing versions (72-6105-03 and 72-6201-09) do not include the hose referenced in steps 5 and 6.

For these versions, connect the dilution fitting directly to the disconnect coupler fitting on the front of the monitor, then connect the 10-inch probe to the dilution fitting.

5. Attach the probe to the female disconnect coupler fitting on the sample hose.
6. Attach the other end of the hose to the female disconnect coupler on the front of the instrument. If you are using the **GT 202**, insert the float switch plug into the float switch jack.



WARNING

Operation of instrument without probe/filter assembly attached will result in pump damage and possible impaired performance. Do not operate without probe/filter assembly attached.

Starting Up the GT

Perform the following steps to start up the GT Series gas monitor and adjust internal circuits to “fresh air” readings (demand zero). Please read this entire section before turning on the GT.

If you are starting up the **GT 202**, refer to the section titled, “Monitoring for Gases (GT 202 only)”.



WARNING

Perform the following start-up procedure in a “fresh air” environment only (environment known to be free of toxic gases, combustible gases, and of normal oxygen content).

1. If you are using Ni-Cd batteries, make sure the batteries are fully charged before you continue this procedure.
2. Press the **ON/OFF** button once, then release the button.

The display momentarily shows the software version of your monitor and the number of data logging hours that remain in memory. During the warm-up period, the gas readings stabilize for the installed sensors. You can hear the pump operating, and the words **WARMING UP** are displayed. The red LED flashes slowly during warm-up. Allow one minute for the display to stabilize and the LED to stop flashing. The GT sounds a periodic beep, and the display shows the words **WARMUP COMPLETE** when the GT completes initial warm-up.



WARNING

Do not perform the next step in the monitoring area. This can place you in potential danger if hazardous conditions exist.

3. Press and hold the **ADJUST/ENTER** button to adjust the monitor to “fresh air” readings. When the display reads **DONE. THANK YOU**, release the button.
4. Verify that the GT displays the correct fresh air reading for each of the GT’s channels.

Table 3-1 lists the correct fresh air reading for **all** channels available for the GT Series gas monitor. Your GT may not include all of the channels listed below.

Table 3-1 GT Fresh Air Readings

Channel	Fresh Air Reading
LEL/ppm	000
O ₂	20.9
CO	000
H ₂ S	000
Cl ₂	00.0
NH ₃	000
SO ₂	00.0



NOTE

If your GT includes an oxygen (O₂) channel, verify the normal operation of the O₂ channel by continuing with step 5. If not, go to the next section, “Shutting Off the GT.”

5. Exhale over the inlet of the probe. The O₂ reading decreases.
6. Continue exhaling over the probe until the O₂ reading decreases to **19.5%** or below.
7. Verify that the alarm activates when the O₂ reading decreases to **19.5%**.
The buzzer sounds, the O₂ reading flashes, and the display flashes **ALRM** when the alarm activates.
8. Verify that the O₂ reading returns to **20.9%**. The gas reading flashes until it increases above 19.5%.

The GT responds to environmental conditions as described in Chapter 4, Operation.

Shutting Off the GT

To turn the GT Series gas monitor off, press the **ON/OFF** button and hold it down while the GT sounds five audible beeps. The monitor automatically shuts off. Release the button.

If your GT uses rechargeable Ni-Cd batteries, the batteries must be fully charged before each use. When using alkaline batteries with your GT, for best possible operation you may choose to install fresh batteries before each use.

See Chapter 6, Maintenance, to recharge Ni-Cd batteries.

OPERATION

This chapter describes the GT Series gas monitor in normal operation. This chapter also describes the GT in warn, alarm, and other operations that can occur during use; how these situations are displayed on the GT; and describes your required responses to these conditions.



CAUTION

Always follow established procedures for an alarm situation. If such procedures do not exist, establish an appropriate plan of action for your application.

Normal Operation

Normal operation is defined as any time:

- the start-up procedure is complete
- the monitor is sampling as designed
- no abnormal indications are on the display
- no audible alarms are occurring

During normal operation, the GT Series gas monitor simultaneously monitors for all target gases for your configuration of the GT.

Monitoring Gases (except GT 202)

To monitor for the target gas(es), expose the probe to the area to be monitored. You can leave the GT monitoring for an entire workday. The GT monitors and displays all applicable gas conditions at the same time.



CAUTION

If your GT includes an ammonia (NH₃), chlorine (Cl₂), or sulfur dioxide (SO₂) sensor, avoid moisture accumulation. The target gas is absorbed by moisture. Replace the probe's hydrophobic filter and cotton ball if you use the GT in an environment where moisture might accumulate.

Monitoring Gases (GT 202 only)

To monitor for combustible gas or O₂, expose the probe to the area to be monitored. You can leave the GT monitoring for an entire workday. The GT monitors and displays all applicable gas conditions at the same time.

When using the GT 202 in tanks and vessels, perform the following steps to test whether or not you need to open the dilution port when monitoring for hydrocarbons.

1. Connect the dedicated sample hose and the float switch plug to the GT 202, then switch the monitor on (see Figure 4-1).
2. Perform an oxygen test by **slowly** lowering the hose and float-probe into the tank or vessel. **Do not lower the probe quickly or you may defeat the float switch.** Hold your finger over the port in the dilution fitting, and observe the % OXY reading.
3. If the reading falls below 10.0%, leave the dilution port open to acquire an accurate hydrocarbon reading.



NOTE

If you calibrated the GT 202 without the dilution fitting in place, double the observed hydrocarbon reading when the dilution port is open.

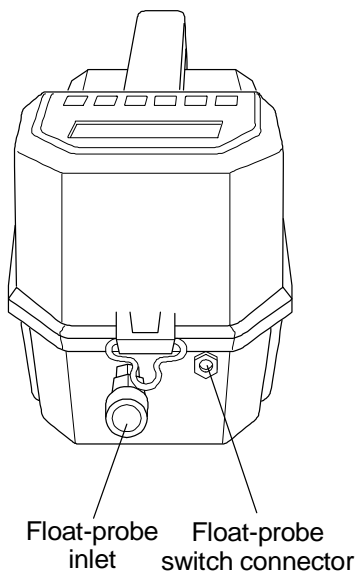

Figure 4-1 Location of Float Switch Jack

Comfort Beep

The GT periodically sounds a short beeping tone. This “comfort beep” is simply an indication that the monitor is functioning normally. See Appendix B, GT Configuration, if you want to turn the “comfort beep” **off**.

Figure 4-2 shows the display screen in normal operation.

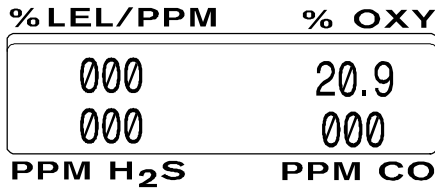

Figure 4-2 GT Normal Operation Display



NOTE

The displays illustrated in this chapter reflect displays for the GT 402 and are intended as examples. The display of your GT Series gas monitor may be slightly different depending on the GT model you are using. The audible and visual alarms are the same for all GT models.

Operator Indications

When a warn, alarm, or other condition causes the GT Series gas monitor to reach any of its preset levels, the monitor senses the condition. During these situations, the GT alerts you with visual and audible alarms. Warn, alarm, and other possible operator indications, the probable cause(s), and your recommended actions are described in this section.

Warn Indication

A warn indication occurs when a preset warn level is reached.

Visual Indications: As shown in Figure 4-3, the gas reading of the channel in warn condition flashes, and the word **WARN** is shown on the display. The red LED flashes in a steady pattern.

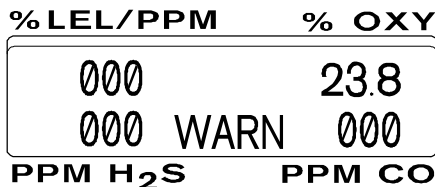

Figure 4-3 GT Warn Display

Audible Indication: The buzzer sounds an even, slow pulsing pattern.

Recommended Actions: As long as the alarms continue, follow the established procedures for a warn condition. The GT is set for a self-reset or latching alarm function.

- **In the self-reset mode**, when the gas reading of the affected channel returns to the normal level, the GT automatically stops and resets its alarms.
- **In the latching mode**, the alarm continues until you press the **RESET** button, even though the gas reading may have returned to the normal level.

Always determine the cause of any warning situation you may encounter.

Alarm Indication

An alarm indication occurs when a preset alarm level is reached.

Visual Indications: As shown in Figure 4-4, the gas reading of the channel in alarm condition flashes, **ALRM** is shown on the display, and the red LED flashes in a steady pattern.

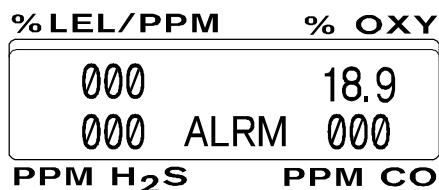

Figure 4-4 GT Alarm Display

Audible Indication: The buzzer sounds at a rapid rate.

Recommended Actions: As long as the alarms continue (self-reset or latching mode), follow the established procedures for an alarm condition.

Always determine the cause of any alarm situation you may encounter.

Float-Probe Related Alarms (GT 202 only)

If the float switch detects the presence of liquid, the visual indicator **PUMP OFF PRESS RESET** displays and the buzzer sounds continuously.



NOTE

After you raise the float-probe, you must press the **RESET** button to restart the pump. You may also need to perform other troubleshooting procedures. See the section titled, “Low Flow Indication”.

Fail Indication

A fail indication occurs when a sensor or other circuitry in the GT no longer functions normally.

Visual Indications: As shown in Figure 4-5, **FAIL** is shown on the display, and the red LED is continuously lit.

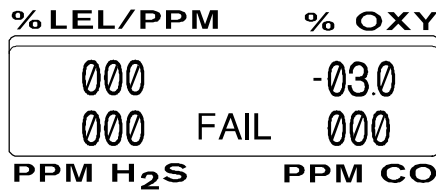

Figure 4-5 GT Fail Display

Audible Indication: The buzzer sounds continuously.

Probable Cause: Any of the following situations may have occurred:

- missing or bad sensor(s)
- missing or bad sensor connection
- down-scale reading (-10% of each full-scale or more)
- internal circuit fault

Recommended Actions: Remove the GT from the monitoring environment. Refer to the troubleshooting information in Chapter 6, Maintenance.

Low Flow Indication

A low flow indication occurs when the normal, measured flow of the sample is interrupted. The GT's pump automatically shuts off in a low flow situation.

Visual Indications: The display alternates between two screens. As shown in Figure 4-6, the first screen shows **PUMP OFF PRESS RESET**. The main display is then shown. The red LED is continuously lit.

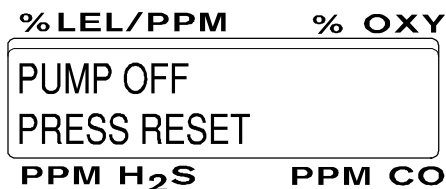

Figure 4-6 GT Low Flow Display

Audible Indication: The buzzer sounds a long pulsing tone.

Probable cause: Any of the following situations may have occurred:

- liquid has been drawn into the probe
- an obstruction has been drawn into the probe, hose, or internal filter or flow system
- internal circuit fault
- a sensor is not installed properly within its cavity in the flow block
- the pump is defective

Recommended Actions: Clear away any visible obstruction from the probe and hose, then press the **RESET** button in order to restart the pump. If the pump restarts, and the monitor functions normally, the problem was momentary. If the indications remain, turn the monitor off, then investigate the probe, hose, or internal flow system for obstructions or a dirty filter.



WARNING

Do not operate the GT without the probe/filter assembly attached.

Low Battery Indication

A low battery indication occurs if the battery voltage drops below the battery alarm threshold.

Visual Indication: The display alternates between two screens. As shown in Figure 4-7, the first screen shows **LOW BATTERY**. The main display is then shown. The red LED is continuously lit. You cannot clear this display.

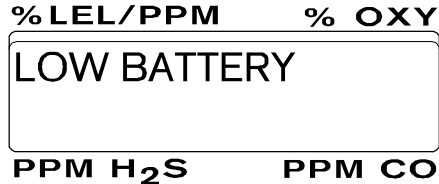

Figure 4-7 GT Low Battery Display

Audible Indication: The buzzer sounds continuously.

Probable Cause: The batteries have reached the end of useful life.

Recommended Action: You must replace the alkaline or recharge the Ni-Cd batteries within your monitor before putting it back into operation. See Chapter 6, Maintenance, for procedures to replace or recharge your batteries.



WARNING

Always replace or recharge batteries in a non-hazardous environment, free of combustible or toxic gas content and consisting of normal oxygen content.

CALIBRATION

This chapter contains instructions to prepare the calibration kit and calibrate the GT Series gas monitor.



WARNING

Accurate calibration of the GT Series gas monitor is essential to ensure correct readings of gas and oxygen concentrations. Incorrect or improper calibration can impair the performance of the instrument and place you in potential danger if hazardous conditions exist.

Preparing the Calibration Kit



CAUTION

Calibrate the GT in a “fresh air” environment (known to be of normal oxygen content and free of toxic or combustible gases). Do not begin calibration unless you can verify that you are in a “fresh air” environment.

Perform the following steps to prepare the GT calibration kit.



WARNING

LEL response will vary for different gases. For best accuracy, LEL calibration should be done using the target gas of the LEL/ppm sensor. (Expected relative combustible responses, listed in Appendix C, Interference Factors, are not verified by UL.)

1. Verify that the calibrating area contains a level surface to set the GT and calibration kit accessories upon.
2. Turn on the GT instrument. Enter the Function program and verify that the Battery Capacity screen displays at least three bars. (See “Displaying Battery Capacity” in Appendix B for a detailed description.)
3. Carefully screw the threaded end of the regulator into the gas cylinder.
4. Attach the sample tubing over the fitting on the regulator.

Calibrating the GT

This procedure describes calibration for a GT that contains the maximum of four sensors. If your GT does not contain four sensors, disregard steps that do not apply.

Entering Calibration Mode

1. Turn on the GT. Allow at least one minute for the GT to stabilize. The red LED stops flashing, and the display reads **WARMUP COMPLETE** when the GT is stabilized. Attach the probe to the inlet fitting on the GT.
2. Press the **ADJUST/ENTER** button. The display shows the main screen.
3. Press the **RESET** and **BACK LITE/-** buttons simultaneously three times. The GT displays:

Version N.NN
Calibrate

Setting the Zero Readings



NOTE

During a zeroing operation, an exclamation point (!) may appear at the beginning of the second line of the display reading when the reading is centered in the zero range.

The ! symbol represents the optimum reading.

1. Press the **ADJUST/ENTER** button. The GT displays:

Zero Gas
NNN PPM H2S

2. Use the **FUNC./+** or **BACK LITE/-** buttons to adjust the display reading to **000 PPM H2S**.
3. Press the **ADJUST/ENTER** button to save this zero setting. The GT displays:

Zero Gas
NNNN PPM COMB

**NOTE**

When zeroing the combustible gas channel, the ppm reading is shown, even if the original display reading was a % LEL reading because zeroing the ppm reading is more accurate than zeroing the % LEL reading.

As you adjust the zero reading for the combustible gas channel, the reading may change by up to 300 ppm each time you press the button. Once you near zero, observe the reading each time you press the button. Do not hold the button down because the reading may proceed past zero too quickly.

4. Use the **FUNC./+** or **BACK LITE/-** buttons to adjust the display reading to **0000 PPM COMB**.
5. Press the **ADJUST/ENTER** button to save this zero setting. The GT displays:

Zero Gas
NNN PPM CO

6. Use the **FUNC./+** or **BACK LITE/-** buttons to adjust the display reading to **000 PPM CO**.
7. Press the **ADJUST/ENTER** button to save this zero setting. The GT displays:

Zero Gas
NN.N %VOL OXY

8. Attach the tubing from the regulator to the probe tube. The GT will draw gas from the gas cylinder.
9. Allow at least one minute, then use the **FUNC./+** or **BACK LITE/-** buttons to adjust the display reading to match the O₂ value marked on the gas cylinder.
10. Press the **ADJUST/ENTER** button to save this setting. The GT displays:

Span Gas
NNN PPM H2S

Setting the Span Readings

1. Use the **FUNC./+** or **BACK LITE/-** buttons to adjust the display reading to match the H₂S value marked on the gas cylinder.
2. Press the **ADJUST/ENTER** button to save this span setting. The GT displays:

Span Gas
NNN %LEL COMB

3. Use the **FUNC./+** or **BACK LITE/-** buttons to adjust the display reading to match the combustible gas value marked on the gas cylinder.
4. Press the **ADJUST/ENTER** button to save this span setting. The GT displays:

Span Gas
NNN PPM CO

5. Use the **FUNC./+** or **BACK LITE/-** buttons to adjust the display reading to match the CO value marked on the gas cylinder.
6. Press the **ADJUST/ENTER** button to save this span setting. The GT displays:

Span Gas
NN.N %VOL OXY

7. Disconnect the probe from the tubing leading to the regulator. The flow of gas will stop automatically.
8. Use the **FUNC./+** or **BACK LITE/-** buttons to adjust the display reading to **20.9 %VOL OXY**.
9. Press the **ADJUST/ENTER** button to save this span setting.

Calibration is now complete. The GT displays:

Exit
Press any Key...

Exiting Calibration Mode

1. Press any button, except the ON/OFF to exit calibration mode.
2. Unscrew the regulator from the gas cylinder.
3. Store the components of the calibration kit in the storage case.

The GT is now ready for normal operation and will function as described in Chapter 4, Operation.

MAINTENANCE

This chapter contains maintenance information to ensure proper operation and reliability of the GT Series gas monitor.



WARNING

Perform all maintenance in a non-hazardous environment free of combustible or toxic gas and consisting of normal oxygen content.

Preventive Maintenance

The following are daily, monthly, quarterly, and “as required” preventive maintenance suggestions to ensure the reliability of the GT Series gas monitor.



NOTE

In instances where the GT is in continual or everyday use, **Thermo GasTech** recommends that you perform preventive maintenance procedures more often than suggested in the following sections.

Daily

BATTERIES

The GT should always contain fully-charged Ni-Cd batteries or sufficiently powered alkaline batteries before each day’s use. You can verify the capacity of the batteries using the Function program. To verify battery capacity:

1. Verify that the battery slide switch is at the proper **ALK** or **NI-CAD** setting for the type of batteries in the GT.
2. Press and hold the **FUNC./+** button, for four beeps, then release the button.

If the display shows less than three bars, recharge the Ni-Cd batteries or replace the alkaline batteries as described later in this chapter.

3. Press the **FUNC./+** button to return to the main display.

CALIBRATION

For **optimum** efficiency of the monitor, calibrate the GT **before** and **after** each use. If multiple calibrations over a period of days indicate that only a minimum of adjustments are required, the frequency of calibration can be changed to weekly or monthly, depending on how often the monitor is used, and how demanding the monitoring environment is.



NOTE

At the very least, “challenge” the normal operation of the oxygen (O₂) sensor (if applicable) before every use.

Exhale over the inlet of the probe as you watch the display. The O₂ reading should **decrease**. When the O₂ reading decreases to **19.5%**, the alarm should activate. This confirms normal operation of the O₂

SAMPLE-DRAW SUBCOMPONENTS

Verify the proper operation of the flow alarm circuit by holding your finger over the inlet of the probe for a few seconds. The pump shuts off, the **PUMP OFF PRESS RESET** message appears on the display, and the audible alarm sounds if the flow alarm circuit is operating properly.

Monthly/Quarterly

CALIBRATION

Calibrate the sensors at least every one to three months. Calibration frequency depends on the frequency of use and also the environmental conditions in which you use the GT.

As Required

ALARM CIRCUITS

Periodically verify that all visual and audible alarms function properly.



WARNING

Verify alarm circuits in a “fresh air” environment only (environment known to be free of combustible and toxic gases and of normal oxygen content).

To verify the alarm circuits, use a concentration of the proper gas sample that is greater than the preset warn or alarm levels. Verify that **WARN** or **ALRM** displays and the buzzer sounds. Also verify that the display reading in alarm flashes during the alarm sequence.

SAMPLE-DRAW SUBCOMPONENTS

Periodically check the probe, hoses, internal filter, and tubing for obstructions that can accumulate over time. *This is especially important if you use the GT in a dusty or dirty environment.* Replace the cotton and hydrophobic filter elements if they become contaminated or discolored.



WARNING

Do not operate the GT without the probe/filter assembly attached.

Troubleshooting



NOTE

See Chapter 4, Operation, for any of the various alarm indications that you may encounter while the GT Series gas monitor is in normal use.

The troubleshooting section describes symptoms and probable causes and recommends action for problems you may encounter with the GT.

Table 5-1 Troubleshooting

Condition	Symptom(s)	Probable Cause(s)	Recommended Action
Unable to recharge Ni-Cd batteries	<ul style="list-style-type: none"> The battery charger does not indicate that the batteries are receiving a charge. After recharging, the batteries do not have a sufficient charge. 	<ul style="list-style-type: none"> The battery selector switch is set to ALK. The batteries are not installed or alkaline batteries are installed. The batteries are defective. The battery charger is defective. 	<ol style="list-style-type: none"> Verify that the battery selector switch is set to NI-CAD. Verify that Ni-Cd batteries are installed. Replace the batteries. Attempt to recharge the batteries with a different battery charger (same type). If the condition clears, the battery charger is defective. If the difficulty continues, contact Thermo GasTech, for further instruction.
Unable to use the battery charger as a continuous operation adapter	<ul style="list-style-type: none"> You cannot operate the GT with the battery charger/continuous operation adapter in place. The display indicates DISCONNECT CHARGER. 	<ul style="list-style-type: none"> The battery selector switch is set to ALK. The batteries are not installed or alkaline batteries are installed. The battery charger is supplying a voltage that is too high. The battery charger is defective. 	<ol style="list-style-type: none"> Verify that the battery selector switch is set to NI-CAD. Verify that Ni-Cd batteries are installed. If you are using the battery charger as a continuous operation adapter for longer than an 8-hour period, disconnect then reconnect the battery charger to restart the timer. Replace the batteries. Use a different battery charger (same type) as a continuous operation adapter. If the condition clears, the battery charger is defective. If the difficulty continues, contact Thermo GasTech, for further instruction.

Table 5-1 Troubleshooting (Continued)

Condition	Symptom(s)	Probable Cause(s)	Recommended Action
Unable to calibrate a sensor (except O ₂ sensor)	<ul style="list-style-type: none"> You cannot set the sensor's "fresh air" reading to zero. You cannot set the applicable gas reading to match the value of the calibrating gas during calibration. 	<ul style="list-style-type: none"> The gas cylinder is empty or out-dated. The sensor is defective. 	<ol style="list-style-type: none"> Verify that the gas cylinder contains an adequate and fresh supply of the calibrating gas. Replace the sensor as described later in this chapter. If the difficulties continue, contact Thermo GasTech, for further instruction.
Unable to calibrate a sensor (O ₂ sensor only)	<ul style="list-style-type: none"> You cannot set the "fresh air" O₂ reading to 20.9. You cannot zero or set the O₂ reading to 12% during calibration. 	<ul style="list-style-type: none"> The gas cylinder is empty or out-dated. The O₂ sensor is defective. 	<ol style="list-style-type: none"> Verify that the gas cylinder contains an adequate and fresh supply of the calibrating gas. Replace the O₂ sensor as described later in this chapter. If the difficulties continue, contact Thermo GasTech, for further instruction.

Recharging Ni-Cd Batteries



WARNING

Recharge the batteries only in a non-hazardous environment.

Check Ni-Cd battery capacity by using the Function program (see Appendix B, GT Configuration).



CAUTION

For optimum battery capacity, the batteries should be fully depleted before you recharge them. Repeated recharging of partially discharged batteries will reduce the battery capacity and operating time of the batteries.

Use only the battery chargers listed in Appendix A, Parts Lists, to recharge the batteries.

1. Verify that the battery selector switch is set to **NI-CAD**.
2. Verify that the voltage listed on the battery charger is the same as the AC outlet (115V or 220V), then plug the charger into the outlet.
3. Plug the other end of the charger into the **CHGR** jack at the side of the GT.

The amber light on the battery charger turns on when the battery charger begins recharging the batteries.



NOTE

The battery charger includes a recognition feature that protects you from attempting to recharge alkaline batteries.

If you attempt to recharge alkaline batteries, the amber light begins flashing and the battery charger terminates the recharging process after approximately one minute.

4. When the batteries are fully recharged, the green light turns on (the amber light remains on.)

A completely depleted battery recharges in approximately eight hours. The battery charger automatically cuts the charging current to a sustaining rate when the batteries are fully recharged. You can leave the charger plugged in indefinitely.

Replacing Components

This section includes procedures to remove and replace the sensors, batteries, pump, and filters. See Figures 6-1 and 6-2, where appropriate, when performing the following procedures.

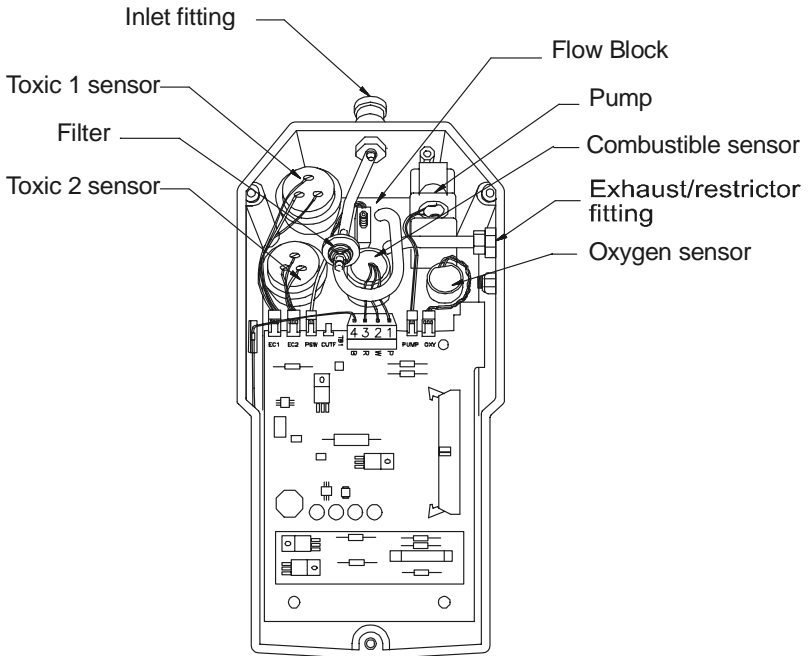

Figure 6-1 GT Series Sensor Locations and Connection Assignments

Replacing Sensors



WARNING

Recalibrate the GT whenever you replace a sensor.



WARNING

If applicable, follow all federal, state, or local regulations regarding the disposal of electrochemical sensors. The toxic sensors contain sulfuric acid. The O₂ sensor contains an alkali solution.

1. Turn off the GT.
2. Open the GT, then separate the two halves.
3. Locate the sensor you want to replace in the flow block (see Figure 6-1).



NOTE

Figures 6-1 and 6-2 illustrate sensor assignments for the GT 402. The sensor assignment for your GT may be different depending on the GT model you are using. Empty sensor cavities are filled with sensor plugs for models that have less than four sensors.

4. Disconnect or unplug the sensor's connection to the GT.

For the combustible gas sensor, disconnect the wiring from terminals **1**, **2**, and **3** of the terminal block (**TB1**). Do not remove the black wire that is connected to terminal **4**.

For the remaining sensors, unplug the applicable sensor wire connector from its socket (**OXY**, **EC1**, or **EC2**).



CAUTION

If you use a tool to loosen the sensor from the flow block, be careful not to damage the sensor housing or the flow block.

5. Using your fingers, tilt the sensor from side to side to loosen it, then pull the sensor straight out of its flow block cavity (see Figure 6-2).

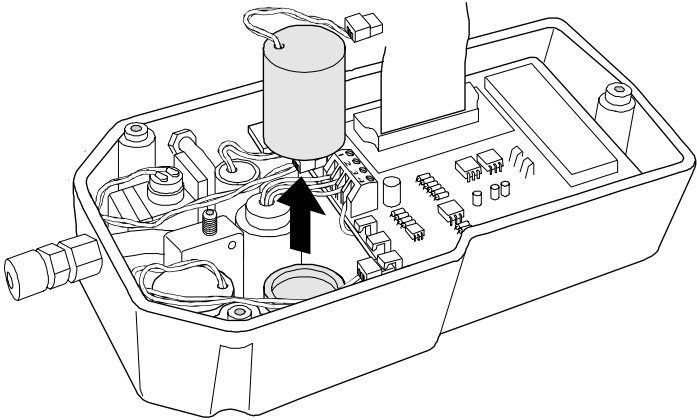

Figure 6-2 Removing a Sensor from the GT

6. Insert the replacement sensor into the cavity, then apply downward pressure on top of the sensor until it is firmly seated in the cavity.
7. Reconnect the sensor's connection to the GT.

For the combustible gas sensor, connect the purple, white, and red wires to the proper terminals (**P**, **W**, **R**) on the terminal block (**TB1**).

For the remaining sensors, plug the sensor wire connector into the applicable socket (**OXY**, **EC1**, or **EC2**).

8. Close the GT, then turn on the GT.



CAUTION

Some toxic gas sensors require a stabilization period. Allow the Cl_2 , NH_3 and SO_2 sensors to stabilize for one hour before you turn on and calibrate the GT.

9. Calibrate the GT before you use it again.

Replacing Alkaline or Ni-Cd Batteries



WARNING

Thermo GasTech recommends use of heavy duty batteries only. Use of other types of batteries may result in shorter operating time.

When replacing Ni-Cd batteries, use only the batteries supplied by Thermo GasTech (refer to Appendix A, Parts List). They are a special, high capacity type. Replace batteries in a non-hazardous environment only.

To Maintain CSA (Canadian Standards Association) certification of your GT series monitor, only replace the batteries with the type specified below:

- **Duracell (PC1300 or MN1300)**
 - **Eveready (EN95)**
 - **SAFT (VEDCFG)**
-

1. Turn off the GT by pressing and holding the **ON/OFF** button while the GT sounds five beeps.
2. Use a 1/8" hex wrench (provided) to turn the captive screw at the middle of the battery compartment door counterclockwise, then remove the door.
3. Remove all four spent batteries.
4. Verify that the **ALK/NI-CAD** switch is set to the proper setting (see Figure 6-3).
5. Install the new batteries. Refer to the raised picture in the battery compartment for the proper orientation of the batteries. **Always** replace **all** four batteries at the same time.
6. Install the battery compartment door and tighten screw until snug against gasket.



WARNING

Replace batteries only in a "fresh air" environment. Never mix Ni-Cd batteries together with alkaline batteries. This can cause internal damage to the monitor. If applicable, follow all federal, state, or local regulations regarding the disposal of alkaline or Ni-Cd batteries.

The toxic gas sensor(s) takes approximately 15 minutes to stabilize. If your GT contains toxic gas sensors, plan to not use your GT during this time because the readings will be unstable.

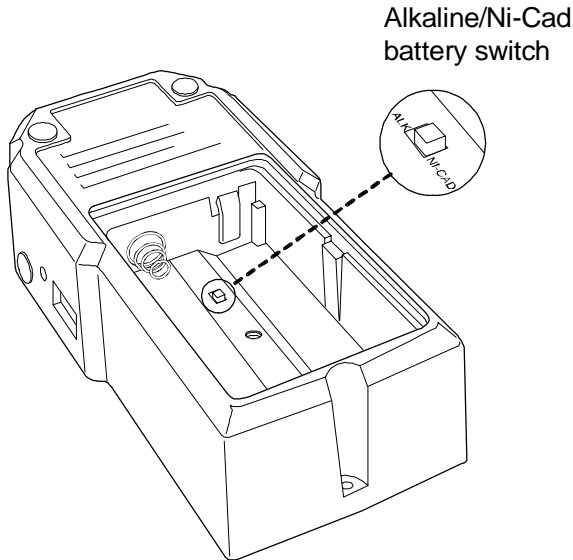

Figure 6-3 GT Series Gas Monitor Battery Compartment

Replacing the Pump

1. Turn off the GT, open the GT, then separate the halves.
2. Locate the pump in the flow block (see Figure 6-1).
3. Disconnect the pump wire connector from the interconnect PCB socket labeled **PUMP**.
4. Remove the nut that secures the pump bracket to the pump, then remove the bracket.
5. Remove the pump from the flow block.



CAUTION

When you insert the new pump, do not place pressure on the pump motor. The pump motor is the dark-colored circular component at the top of the pump.

6. Before installing the new pump, apply a thin film of petroleum jelly lubricant or o-ring grease to the outside of the barbs. Be careful not to get lubricant into the end of the barbs, as this could clog the pump.



CAUTION

Do not use lubricant that contain silicone, as this can damage the catalytic sensor.

7. Place the pump bracket in its previous position, then secure the bracket to the pump with the nut you removed in step 4.
8. Reconnect the pump wire connector to the PCB socket labeled **PUMP**, then close and secure the GT.

Replacing the Internal Filter

1. Turn off the GT, open the GT, then separate the halves.
2. Locate the internal filter (see Figure 6-1). It is connected to the inlet fitting by a small polyurethane tube.
3. Disconnect the polyurethane tubes from the slip-on barbs on the filter.
4. Push the tubes onto the barbs on the new filter, then close and secure the GT.

Replacing the Probe's Hydrophobic Filter

1. Unscrew the probe body's two halves. Be careful not to lose the o-rings that seal the filter.
2. Remove the filter and cotton ball from the probe half that mounts to the GT. (You may need to use a small screwdriver to pry the filter loose.)
3. Install the new filter and cotton ball in place of the filter and cotton ball you removed.
4. Make sure the o-rings are in place, then reassemble the probe halves.

Appendix
A

PARTS LIST

Table A-1 lists part numbers for all GT Series models.

Table A-1 GT Series Gas Monitors

Part No.¹	Description
72-6101	GT Series, Oxygen
72-6105	GT Series, Combustible (LEL/PPM)
72-6105-03 ²	GT Series, Transformer Testing, Combustible, Alkaline
72-6106	GT Series, Ammonia
72-6107	GT Series, Chlorine
72-6201	GT Series, Combustible (LEL/PPM), O ₂
72-6201-09 ²	GT Series, Transformer Testing, Combustible/O ₂ , Alkaline
72-6202	GT Series, Float Probe, Comb.(LEL/PPM), O ₂
72-6302	GT Series, Combustible (LEL/PPM), O ₂ , H ₂ S
72-6303	GT Series, Combustible (LEL/PPM), O ₂ , CO
72-6304	GT Series, Combustible (LEL/PPM), O ₂ , SO ₂
72-6305	GT Series, Combustible (LEL/PPM), O ₂ , Cl ₂
72-6402	GT Series, Combustible (LEL/PPM), O ₂ , H ₂ S, CO
72-6404	GT Series, Combustible (LEL/PPM), O ₂ , SO ₂ , CO
72-6405	GT Series, Combustible (LEL/PPM), O ₂ , Cl ₂ , CO
72-6406	GT Series, Combustible (LEL/PPM), O ₂ , H ₂ S, SO ₂

¹ Add -01 for alkaline batteries; add -02 for Ni-Cd batteries.

² Alkaline versions only available for these models 72-6105-03 and 72-6201-09.

Table A-2 lists replaceable parts and accessories for all GT Series.

Table A-2 Replaceable Parts and Accessories, GT Series

Part No.	Description
06-1255	Tubing, polyurethane, 5/16 in. OD x 3/16 in. ID
13-0110	Shoulder strap, adjustable
17-0605	“Y” barb, 1/8 in.
20-0650	Carrying case, GT Series instrument
20-0651	Case, confined space kit (case only)
30-0042	Pump
30-0044	Kit, rebuild pump (30-0042/30-0042-01)
33-0152-01	Hydrophobic filter (for 80-0187 probe)
33-0160	Filter, internal
33-1031	Cotton ball, pkgs. of 24 (for 80-0187 probe)
49-1201	Battery, alkaline, D size
49-1501-01	Battery, Ni-Cd, D size
49-2149	Ni-Cd battery charger, dual-rate, 230 VAC
49-2150	Ni-Cd battery charger, dual-rate, 115 VAC
49-2151	Ni-Cd battery charger, dual-rate, 12 VDC
52-2033	Remote audible alarm, with lapel clip
52-2033-01	Remote audible alarm, with 20-foot cord and magnet
61-0123	Sensor, combustibles (LEL/ppm)
65-0612	Sensor, oxygen (O ₂)
65-2417	Sensor, sulfur dioxide (SO ₂)
65-2426-01	Sensor, carbon monoxide (CO)
65-2426-02	Sensor, hydrogen sulfide (H ₂ S)
65-2431-01	Sensor, chlorine (Cl ₂)
65-2431-07	Sensor, ammonia (NH ₃)
71-4040	Instruction sheet, GT Series Calibration Kits
71-6410	GT Series Operator's Manual
71-6401	GT Series Quick Reference Card
80-0187	Probe with hydrophobic filter
80-0187-04	Probe, fiberglass, 30-inch, with hydrophobic filter
80-0190	Probe with hydrophobic filter (for units with auto-shutoff)

Table A-2 Replaceable Parts and Accessories, GT Series

Part No.	Description
80-0211	Moisture trap
80-0405	Dilution fitting, 50%
80-0504	Hose, polyurethane/teflon, 3 feet (chlorine versions only)
80-0505	Hose, polyurethane, 5 feet
80-0511	Hose, polyurethane, 10 feet
80-0516	Hose, polyurethane, 15 feet
80-0520	Hose, polyurethane, 20 feet
80-0525	Hose, polyurethane, 25 feet
80-0530	Hose, polyurethane, 30 feet
80-0550	Hose, polyurethane, 50 feet
80-0599	Hose, polyurethane, 100 feet
80-0801E-12	Float switch probe assembly for GT 202
81-0154	Gas cylinder, (50% LEL CH ₄ ; 25 PPM H ₂ S; 50 PPM CO; 12% O ₂)
81-0155	Gas cylinder, 103L (50% LEL CH ₄ ; 50 PPM CO; 12% O ₂)
81-0170	Gas cylinder, 5 ppm SO ₂ -in-N ₂
81-0190	Gas cylinder, 5 ppm Cl ₂ in N ₂
81-0191	Gas cylinder, 25 ppm NH ₃ -in-air
81-1069	Regulator, flow matching (3-in-1 and 4-in-1 test gas cylinders)
81-1126	Gas collecting bag w/clamp
81-1134	Gas collecting bag, Tedlar w/clamp and tubing (Cl ₂ versions)
81-6400-01	Calibration kit, 4-in-1 gas cylinder and flow matching regulator
81-6400-02	Calibration kit, 3-in-1 gas cylinder and flow matching regulator
81-6500	Confined space kit, GT Series (non H ₂ S)
81-6501	Confined space kit (any H ₂ S version)
82-0200	1/8" hex wrench
82-5070	Data retrieval option package

GT CONFIGURATION

Setup programs are available that allow you to configure your GT. Each program consists of a sequence of screens that contain adjustable parameter fields. The programs are:

- Instrument Setup program
- Channel Setup program
- Function program

This appendix includes procedures to use each program.

The Instrument Set-Up Program

The Instrument Setup program includes the following parameters. The information in parenthesis are the default settings.

- Time and Date (**U.S. Pacific Standard**)
- Alarm Delay (**1 Second**)
- Data Log Sample (**30 Seconds**)
- When Log Full (**Overwrite Oldest**)
- Comfort Beep (**ON**)
- Instrument ID (**1**)

This section includes procedures to display or adjust these parameters.

Instrument Setup Button Assignments

Use the following buttons on the operator control panel to navigate through and make changes to the Instrument Setup program.

- Use the **RESET** button to cancel changes that you have made to current display parameters or to return to a previous screen of a multi-screen operation.
- Use the **FUNC./+** button to make positive parameter changes or as a “YES” button.
- Use the **BACK LITE/-** button to make negative parameter changes or as a “NO” button.
- Use the **ADJUST/ENTER** button to confirm an existing setting or a change to a setting and to move forward to the next Instrument Setup screen.

Running the Instrument Setup Program

1. Press the **RESET** and **FUNC./+** buttons simultaneously three times to enter the Instrument Setup program.



CAUTION

The pump shuts off when you enter the Instrument Setup program. The GT is not an active gas monitor until you exit the program.

The first line indicates the version of GT Instrument Setup software you are operating:

**Version N.NN
Instrument Setup**

2. Press **ADJUST/ENTER** to continue the program.

DISPLAYING OR ADJUSTING TIME AND DATE

The first screen indicates the current time and date.

**HH:MM:SS
MM/DD/YY**



NOTE

The time is set to U.S. Pacific Standard Time (PST). The GT Series gas monitor uses the 24-hour format to display time. For example, 21:30:00 is 9:30 PM.

- To accept the time and date setting and continue the program, press **ADJUST/ENTER** until the next screen displays.
- To adjust any of the six fields:
 1. Press **ADJUST/ENTER** until the field is flashing.
 2. Press **FUNC./+** or **BACK LITE/-** to adjust the field.
 3. Press **ADJUST/ENTER** until the next screen displays.

DISPLAYING OR ADJUSTING ALARM DELAY

This display indicates the alarm delay setting. The range of the alarm delay setting is 0 through 300 seconds.

Alarm Delay 1 second

- To accept the alarm delay setting and continue the program, press **ADJUST/ENTER**.
- To adjust the alarm delay setting:
 1. Press **FUNC./+** or **BACK LITE/-** to adjust the setting.
 2. Press **ADJUST/ENTER** to continue the program.



WARNING

The indicator LED and audible alarm are not active and will not warn you of possible hazardous gas conditions for the length of the alarm delay setting.

DISPLAYING OR ADJUSTING DATA LOG SAMPLE

This screen indicates the data log sample setting. The data log sample setting is how often the GT stores data in microprocessor memory.

Data Log Sample 30 Seconds

- To accept the data log sample setting and continue the program, press **ADJUST/ENTER**.
- To adjust the data log sample setting:
 1. Press **FUNC./+** or **BACK LITE/-** to adjust the setting.
 2. Press **ADJUST/ENTER** to continue the program.

Table B-1 lists approximately how long it will take to reach data log capacity for each data log sample setting. The time to reach data log capacity depends on the amount of alarm activity.

Table B-1 Data Log Capacity Specifications

Sample Interval	No Alarm Activity	Heavy Alarm Activity
10 seconds	5 hours	3 1/2 hours
30 seconds	15 hours	7 1/2 hours
60 seconds	30 hours	10 hours
5 minutes	6 days	1/2 day

DISPLAYING OR ADJUSTING WHEN LOG FULL

This screen indicates the data log full setting. This setting instructs the microprocessor to either overwrite the oldest data or stop recording new data when the data log is full.

When Log Full Overwrite Oldest

- To accept the data log full setting and continue the program, press **ADJUST/ENTER**.
- To adjust the data log full command:
 1. Press **FUNC./+** or **BACK LITE/-** to display the alternate setting.
 2. Press **ADJUST/ENTER** to continue the program.

DISPLAYING OR ADJUSTING COMFORT BEEP

This screen indicates if the comfort beep is on or off.

Comfort Beep ON

- To accept the comfort beep setting and continue the program, press **ADJUST/ENTER**.
- To adjust the comfort beep setting:
 1. Press **FUNC./+** or **BACK LITE/-** to display the alternate setting.
 2. Press **ADJUST/ENTER** to continue the program.

DISPLAYING OR ADJUSTING INSTRUMENT ID

This screen indicates the ID number of this GT. The ID number is included in the data log.

Instrument ID (0-255)

- To accept the instrument ID setting and continue the program, press **ADJUST/ENTER**.
- To adjust the instrument ID setting:
 1. Press **FUNC./+** or **BACK LITE/-** to change the setting. You can hold the button down to increase the speed of the display.
 2. Press **ADJUST/ENTER** to continue the program.

Exiting the Instrument Setup Program

The final screen shows the following message:

Exit
Press any key...

Press **ADJUST/ENTER** to exit the Instrument Setup program and return to normal operation.

The Channel Set-Up Program

The Channel Setup program includes the following parameters for each channel of the GT Series gas monitor:

- Channel Status (active, silenced, or non-active)
- Target Gas
- Unit of Measure (ppm, %LEL, %VOL)
- Fullscale Value
- Alarm Settings (setpoint, alarm action, and alarm activation)

This section includes procedures to display or adjust these parameters.

Running the Channel Setup Program



NOTE

The screens illustrated in this section are examples only and may not **exactly match** the screens displayed by your GT model.

1. Press the **RESET** and **ADJUST/ENTER** buttons simultaneously three times to enter the Channel Setup program.



CAUTION

**The pump shuts off when you enter the Channel Setup program.
The GT is not an active gas monitor until you exit the program.**

The first line indicates the version of GT Channel Setup software you are operating:

Version N.NN
Channel Setup

2. Press **ADJUST/ENTER** to continue the program.



NOTE

The block cursor is always on or to the left of the currently modifiable line.

DISPLAYING OR ADJUSTING CHANNEL STATUS

The first screen indicates the status of Channel 1.

Channel 1 ACTIVE/ ONLINE

- To accept the channel status setting and continue the program, press **ADJUST/ENTER**.
- To adjust the channel status setting:
 1. Press **FUNC./+** or **BACK LITE/-** to display the setting you want.
The three available settings are:
 - **ACTIVE/ONLINE**: This is the normal setting. In this setting, the display shows the current gas concentration, the GT stores data in microprocessor memory, and the status LED and audible alarms are active.
 - **SILENCED/OFFLINE**: In this setting, the display shows **XXX** in place of the gas concentration reading, the GT stores data in microprocessor memory, and the status LED and **all** audible alarms are turned off. Use this setting to temporarily deactivate a channel.
 - **NO SENSOR/AMP**: In this setting, the display for this channel is turned off, and the status LED and all audible alarms are also turned off. Use this setting if a channel is either empty or defective.
 2. Press **ADJUST/ENTER** to continue the program.

DISPLAYING OR ADJUSTING CHANNEL 1 SETUP

This message asks you to accept or change the parameters of the channel:

Setup Channel?

- To accept the channel parameters, press **RESET**. The channel status screen for the next channel is displayed, if applicable.
- To display or adjust the channel parameters, press **ADJUST/ENTER**.

DISPLAYING OR ADJUSTING FULLSCALE, UNIT OF MEASURE, AND TARGET GAS

This screen indicates the fullscale value, unit of measure, and target gas of the channel.

10,000 PPM COMB

- To accept the fullscale value, unit of measure, and target gas settings and continue the program, press **ADJUST/ENTER**.
- To adjust the full scale value:
 1. Press **ADJUST/ENTER** to move the flashing cursor to the left of the fullscale value.
 2. Press **FUNC./+** or **BACK LITE/-** to adjust the setting.
 3. Press **ADJUST/ENTER** to continue the program.



CAUTION

You must recalibrate if you change the fullscale value. Verify and change (if necessary) the warn and alarm setpoints if you change the fullscale value.

- To adjust the target gas setting:



NOTE

You can only adjust the target gas setting for toxic gas channels. The target gas setting must match the sensor installed in the toxic gas channel.

1. Press **FUNC./+** or **BACK LITE/-** to adjust the setting.
2. Press **ADJUST/ENTER** two times to continue the program.

DISPLAYING OR ADJUSTING WARN SETTINGS

The first line of this screen indicates the warn (WARN) setpoint. The second line indicates the alarm action (LATCH or AutoR) and alarm activation (RISE or FALL) settings.

010 %LEL COMB WARN1 AUTOR RISE

- To accept the warn settings and continue the program, press **ADJUST/ENTER** two times.
- To adjust the warn setpoint:
 1. Press **FUNC./+** or **BACK LITE/-** to adjust the setting.



NOTE

GT Series Sensor Specifications, lists standard warn setpoints for each of the GT's sensors.

2. Press **ADJUST/ENTER** two times to continue the program.
- To adjust the alarm action or alarm activation setting:
 1. Press **ADJUST/ENTER** to move the cursor to the second line of the screen.
 2. Press **FUNC./+** to select the alternate alarm action setting (**LATCH** or **AutoR**).



NOTE

AutoR indicates a self-reset alarm action.

3. Press **BACK LITE/-** to select the alternate alarm activation setting (**RISE** or **FALL**).
4. Press **ADJUST/ENTER** to continue the program.

DISPLAYING OR ADJUSTING ALARM SETTINGS

The first line of this screen indicates the alarm (ALM) setpoint. The second line indicates the alarm action (LATCH or AutoR) and alarm activation (RISE or FALL) settings.

010 %LEL COMB ALM1 AUTOR RISE

- To accept the alarm settings and continue the program, press **ADJUST/ENTER** two times.
- To adjust the alarm setpoint:
 1. Press **FUNC./+** or **BACK LITE/-** to adjust the setting.

**NOTE**

GT Series Sensor Specifications, lists standard alarm setpoints for each of the GT's sensors.

2. Press **ADJUST/ENTER** two times to continue the program.
- To adjust the alarm action or alarm activation setting:
 1. Press **ADJUST/ENTER** to move the cursor to the second line of the screen.
 2. Press **FUNC./+** to select the alternate alarm action setting (**LATCH** or **AutoR**).

**NOTE**

AutoR indicates a self-reset alarm action.

3. Press **BACK LITE/-** to select the alternate alarm activation setting (**RISE** or **FALL**).
4. Press **ADJUST/ENTER** to continue the program.

**NOTE**

If this is a **combustible gas channel**, the Channel Setup program displays warn and alarm screens for PPM settings, then the program begins channel setup for the next channel.

If this is a **toxic gas channel**, the Channel Setup program displays alarm screens for the Time Weighted Average (TWA) and Short Term Exposure Limit (STEL) settings, then the program begins channel setup for the next channel.

If this is an **oxygen channel**, the Channel Setup program begins channel setup for the next channel.

Exiting the Channel Setup Program

1. When the Channel Setup program displays the final alarm screen for the last channel, press **ADJUST/ENTER** until the exit screen displays.

Exit
Press any key...

2. Press **ADJUST/ENTER** to exit the Channel Setup program and return to normal operation.

The Function Program

Use the Function program to:

- display battery capacity
- display time and date
- display log remaining
- display TWA/STEL values
- display minimum/maximum values
- display alarm setpoints
- run a diagnostics test
- reset the data log
- reset minimum/maximum values
- reset TWA/STEL values



WARNING

The indicator LED and alarms are not active while the GT Series gas monitor is in the Function program and will not warn you of possible hazardous gas conditions.

Function Menu Button Assignments

Use the following buttons on the operator control panel to enter, run, and exit the Function program.

- Use the **FUNC./+** button to:
 - enter the Function program
 - select and perform the function you want
 - proceed through additional screens for a particular function.

If you stop at a screen **earlier** than the one you want, continue pressing and releasing the **FUNC./+** button until the screen you want displays.

If you stop at a screen **later** than the one you want, press the **RESET** button to exit the program, then press the **FUNC./+** button to re-enter the Function program.

- Use the **RESET** button to exit the Function program.

Displaying Battery Capacity



WARNING

If you display battery capacity while the GT is in an alarm condition, the GT displays a series of “C’s” in place of the bars illustrated in Figure B-1.

1. Press and hold **FUNC./+** for four beeps.

The GT now displays “Battery Capacity” and a bar graph that indicates the status of the batteries. Ten bars indicate full battery capacity.

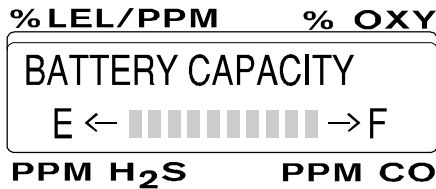

Figure B-1 GT Battery Capacity Display



CAUTION

If three or less bars display, replace (alkaline) or recharge (Ni-Cd) the batteries. When using Ni-Cd batteries, be aware that end-of-life drop-off (and triggering of the low battery alarm) occurs at a quicker rate than when using alkaline batteries.

Due to the nature of alkaline cells, battery life is greatly reduced at low temperature. Ni-Cd batteries are recommended for low temperature applications.

2. Press **FUNC./+** to determine which type of batteries (alkaline or Ni-Cd) are installed. Either **Alkaline Battery** or **Ni-Cd Battery** displays temporarily, then the GT returns to normal operation.



CAUTION

The battery type shown on the display is determined by the setting of the slide switch in the battery compartment. Verify that this switch is at the proper setting for the type of batteries that are installed.

Displaying Time and Date

1. Press **FUNC./+**. The GT begins to scroll through each screen of the Function program.
2. Press and hold **FUNC./+** when the following screen displays:

**Function for...
Date Time**

3. Release **FUNC./+** after the GT sounds three beeps. The GT displays the following screen:

**HH:MM:SS
MM/DD/YY**



NOTE

The time is initially set to U.S. Pacific Standard Time (PST). The GT uses the 24-hour format to display time.

For example, 16:30:00 indicates 4:30 PM.

See the “Instrument Setup Program” section earlier in this chapter to update the time or date setting.

4. Press **RESET** to exit the Function program and return to normal operation.

Displaying Data Log Remaining

1. Press **FUNC./+**. The GT begins to scroll through each screen of the Function program.
2. Press and hold **FUNC./+** when the following screen displays.

**Function for...
Log Remaining**

3. Release **FUNC./+** after the GT sounds three beeps. The GT displays the following screen.

**Log Remaining...
NN.N Hours**

4. Press **RESET** to exit the Function program and return to normal operation.

Displaying TWA/STEL Values

TWA is the channel's average reading for the past eight hours. STEL is the channel's average reading for the past 15 minutes.



NOTE

The GT displays TWA and STEL for toxic gas channels only.

1. Press **FUNC./+**. The GT begins to scroll through each screen of the Function program.
2. Press and hold **FUNC./+** when the following screen displays.

**Function for...
TWA/STEL Values**

3. Release **FUNC./+** after the GT sounds three beeps. The GT displays the TWA reading for Channel 3 (the first toxic gas channel).

**TWA chan 3
NNN PPM H2S**

4. Press **FUNC./+** to display the STEL reading for Channel 3.
5. Press **FUNC./+** to display the TWA reading for Channel 4.
6. Press **FUNC./+** to display the STEL reading for Channel 4.
7. Press **RESET** to exit the Function program and return to normal operation.

Displaying Min/Max Readings

Min. is a channel's minimum reading since the last time you reset the min/max readings. Max. is a channel's maximum reading since the last time you reset the min/max readings.

1. Press **FUNC./+**. The GT begins to scroll through each screen of the Function program.
2. Press and hold **FUNC./+** when the following screen displays.

**Function for...
Min/Max Values**

3. Release **FUNC./+** after the GT sounds three beeps. The GT displays the minimum reading for Channel 1.

**Min chan 1
NNN %LEL COMB**

4. Press **FUNC./+** to display the maximum reading for Channel 1.
5. Continue pressing and releasing **FUNC./+** to display the minimum and maximum readings for the remaining channels.
6. Press **RESET** to exit the Function program and return to normal operation.

Displaying Alarm Setpoints

This function displays the WARN, ALM, TWA, and STEL setpoints, alarm action (LATCHing or Auto Reset), and alarm activation (RISE or FALL) for the each channel.

1. Press **FUNC./+**. The GT begins to scroll through each screen of the Function program.
2. Press and hold down **FUNC./+** when the following screen displays.

**Function for...
Alarm Setpoints**

3. Release **FUNC./+** after the GT sounds three beeps. The GT displays alarm information for the warn (WARN) level of Channel 1.

**NNN %LEL COMB
WARN1 AUTOR RISE**

4. Press **FUNC./+** to display alarm information for the alarm (ALM) level of Channel 1.
5. Continue pressing and releasing **FUNC./+** to display warn and alarm levels for the remaining channels.



NOTE

The GT displays alarm information for TWA and STEL alarms for toxic gas channels only.

6. Press **RESET** to exit the Function program and return to normal operation.

Running the Diagnostics Test

Use this function to run the GT's self-tests. You should run the diagnostics function periodically.

1. Press **FUNC./+**. The GT begins to scroll through each screen of the Function program.
2. Press and hold down **FUNC./+** when the following screen displays.

**Function for...
Diagnostics**

3. Release **FUNC./+** after the GT sounds three beeps. The GT displays the following screen. A beep sounds as each of the 16 dots displays in the second line.

Self Check

.....

After the last dot displays, you temporarily see a full screen of bars, then the GT returns to normal operation.

Resetting the Data Log



CAUTION

All data is lost and cannot be downloaded after you reset the data log.

1. Press **FUNC./+**. The GT begins to scroll through each screen of the Function program.
2. Press and hold **FUNC./+** when the following screen displays.

**Function for...
Reset Data Log**

3. Release **FUNC./+** after the GT sounds three beeps. The GT displays the following screen, then returns to normal operation.

Resetting Log

Resetting Min/Max Readings



CAUTION

You cannot retrieve previously stored minimum and maximum readings after you perform this function.

1. Press **FUNC./+**. The GT begins to scroll through each screen of the Function program.

2. Press and hold **FUNC./+** when the following screen displays.

**Function for...
Reset Min/Max**

3. Release **FUNC./+** after the GT sounds three beeps. The GT displays the following screen, then returns to normal operation.

Reset Min/Max

Resetting STEL/TWA Readings



CAUTION

You cannot retrieve previously stored STEL and TWA readings after you perform this function.

1. Press **FUNC./+**. The GT begins to scroll through each screen of the Function program.
2. Press and hold **FUNC./+** when the following screen displays.

**Function for...
Reset STEL/TWA**

3. Release **FUNC./+** after the GT sounds three beeps. The GT displays the following screen, then returns to normal operation.

Reset STEL/TWA

INTERFERENCE FACTORS

The following factors interfere with the accurate gas measurement capability of the GT:

- Filament poisoning
- Rich mixtures
- Oxygen-deficient mixtures
- Oxygen-enriched mixtures
- Interfering gases
- Response to various combustible gases

Filament Poisoning

Silicone vapors and chlorine and fluorine compounds, such as chlorinated hydrocarbons, can damage the HC sensor and interfere with accurate LEL readings.

Such compounds, even in small proportions, should be avoided. Verification checks on known gas samples are necessary, if the possibility of exposure to these compounds exists.

High Concentration of Combustible Gas

With rich mixtures of combustible gases, the instrument displays the following indications (refer to Table C-1)

Table C-1 Indications with High Combustible Gas Concentrations

Cause	Indication
Mixtures up to 100% LEL	Reading displayed.
Mixtures between LEL and Upper Explosive Limit (UEL)	OVER displayed in place of the reading.
Mixtures above the UEL	The reading increases to 100% LEL, then comes back down. Very rich mixtures read close to zero.

Oxygen-Deficient Mixtures

Samples containing less than 10% oxygen may give low LEL readings by starving the combustible gas reaction in the sensor. Such mixtures will also cause a low oxygen alarm. As a rule, 10% oxygen or more gives a full reading on any combustible gas up to the LEL.

Oxygen-Rich Mixtures

Samples containing combustible gases that have more than normal proportion of oxygen will give a normal reading. However, they should be avoided because the flame arrestor used is not dense enough to arrest flames from combustible gas in oxygen. Such mixtures will also cause a high oxygen alarm.



WARNING

Do not attempt to use the GT on samples of combustible gas in oxygen; for example, oxy-acetylene mixtures. Instead, use sample mixture in air.

Interfering Gases

The CO sensor responds to some other gases besides CO. The CO sensor has a charcoal filter that prevents interference from H₂S and some of these other gases. However, continuous exposure may saturate the filter and break through as CO indication. Hydrogen, ethylene, and acetylene will pass quickly through the filter, and thus are strong interferences, while heavier olefins and aromatic hydrocarbons will break through in time, making filter replacement necessary.

Relative Combustible Response

The GT is normally calibrated on methane gas, but responds to a variety of hydrocarbons (refer to Table 2).

Table C-2 Relative Response of New GT Series LEL/ppm Hydrocarbon Indicator to Various Gases and Vapors

GAS or VAPOR	LEL RANGE			PPM RANGE	
	% LEL VOL	CONVERSION FACTOR:		CONVERSION FACTOR:	
		VS. HEXANE	VS. METHANE	VS. HEXANE	VS. METHANE
Acetone	2.5	0.73	1.7	1.6	0.48
Acetylene	2.5	0.63	1.5	1.2	0.34
Benzene*	1.2	1.0	2.3	1.0	0.30
Butadiene, 1, 3-	2.0	0.52	1.21	0.98	0.29
Carbon Monoxide	12.5	0.39	0.9	5.9	1.8
Chloroform*	NONE	-	-	9.8	3.0
Dimethyl Formamide*	2.2	1.4	3.3	2.7	0.81
Ethyl Acetate*	2.0	0.9	2.1	1.6	0.48
Ethyl Alcohol	3.3	0.70	1.6	2.1	0.64
Heptane	1.05	1.00	2.3	0.99	0.30
Hexane	1.1	1.00	2.3	1.0	0.30
Hydrogen	4.0	0.33	0.7	1.3	0.39
Methane	5.0	0.43	1.0	3.3	1.0
Methyl Chloroform	7.5	0.68	1.6	4.9	1.5
Methyl Ethyl Ketone	1.4	1.09	2.5	1.7	0.52
Pentane	1.5	0.71	1.7	1.0	0.30
Propane	2.1	0.56	1.3	1.3	0.39
Propyl Acetate*	1.7	0.77	1.8	1.4	0.42
Propyl Alcohol, iso-	2.0	0.89	2.1	1.9	0.58
Propyl Alcohol, n-	2.2	0.81	1.9	1.9	0.58
Styrene Monomer	0.9	4.2	9.7	2.7	0.82
Toluene	1.1	1.2	2.9	1.2	0.36
Trichloroethylene	8.0	1.0	2.4	6.8	2.1
Xylenes, isomer mix	-9-1.1	3.0	7.0	1.7	0.52

* These response factors are estimates, based on factors for 6 volt GasTechTor sensor adjusted for characteristics of GT sensor.

Please note that response varies from one sensor to another and the relative response of a sensor can change with the age of the sensor. These data should be used for estimation purposes only.

Assuming an instrument calibrated directly for hexane or methane, but used to observe a different gas, the equivalent response in % LEL (or ppm) for that gas is secured by multiplying the observed % LEL (or ppm) reading by the LEL (or ppm) scale conversion factor.

SUPPLEMENTAL INSTRUCTIONS

GT Land Surveyor

The GT Land Surveyor consists of two different models (PPM/LEL/% and PPM/%/%) that permits measurements of methane gas in three ranges of sensitivity:

Table D-1 Ranges for GT Land Surveyor

PPM/LEL/%	PPM/%/%
0-10,000 PPM	0-10,000 PPM
0-100% LEL	0-5.0% Gas by VOL (%LO), equivalent to 0-100% LEL
0-100% Gas by VOL*	0-100% Gas by VOL (%HI)*

* By means of Thermal Conductivity Sensor

PPM/LEL/%

For the PPM/%/%, see the text in brackets [].

Operation in the first two ranges is exactly as described in the text of this manual, except that if the PPM reading should exceed its range (10,000 PPM) the range will automatically switch to the LEL [%LO] range. If the LEL [%LO] reading should exceed 100% LEL, equivalent to 5% methane, the GT Land Surveyor will automatically switch to the 0-100% Gas range [%HI] range. The display will show the legend “% GAS” [%HI] following the gas reading while in this range.

The % Gas [%HI] range may also be entered manually from the LEL [%LO] range by holding down the RANGE button until the display begins to cycle from LEL [%LO] to PPM to % Gas [%HI] indication, then releasing the button when the display shows the desired range. (From the PPM range, first press the range switch once to enter the LEL [%LO] range, the proceed as above.) If it is likely that high concentrations will be encountered, start out in the % Gas [%HI] range and then switch range if necessary. The Land Surveyor does not automatically range down. To exit the % Gas [%HI] range and return to the LEL [%LO] range press the RANGE button. There is a 30 second warm-up period after the transition, during this period the display will blink.



NOTE

If the sample is very high in methane content and also very low in oxygen content, the unit may not auto-range upscale. If during sampling the LEL [%LO] indication rises rapidly and then decays, manually switch to the % Gas [%HI] range as described above to determine the methane content.



CAUTION

All alarms, including oxygen and toxic sensor alarms, are suppressed while operating in the % Gas [%HI] mode. The Land Surveyor does not automatically range down. To exit the % Gas [%HI] range and return to the LEL [%LO] press the RANGE button. There is a 30 second warm-up period (display will blink) after the mode transition. To prolong the life of the LEL/PPM [%LO/PPM] sensor, avoid switching to the LEL [%LO] range when the gas level is known or expected to be greater than 2.5% methane (50% LEL). In versions furnished with carbon monoxide (CO) measurement, there may be brief transitory CO readings during mode transition, which should be ignored.

Precautions

Be aware that the methane/air mixtures in the range 5% to 15% by volume are highly explosive. The GT is Intrinsically Safe, and is not a source of ignition, but there are many common ignition sources such as static electrical discharges or sparks from metal tools that can ignite such mixtures. The relationship between ranges is correct only for methane. Some rough approximations may be made for gases such as propane and butane, but values will not be accurate, and should not be used for safety considerations.



WARNING

Initiate Fresh Air Zero adjustment only in a non-hazardous environment free of combustible or toxic gas content and consisting of normal oxygen content. To do otherwise could cause a serious error in the indicated gas level shown on the display, and result in failure of the GT Land Surveyor to properly indicate the degree of hazard. Also, use care not to initiate Fresh Air Zero immediately after a range change, as this can cause an error in the "clean air" baseline. A re-zero is not normally necessary after a range change.

Calibration

Calibration is as described earlier in this manual, with one exception: the %GAS [%HI] sensor is calibrated separately from the Catalytic (LEL/PPM or %LO/PPM) sensor. The Calibration Procedure begins with the GT in the LEL [%LO] mode, proceeding as in the manual through the LEL [%LO/PPM], Oxygen, and Toxic, Zero and Span settings on known calibration gas samples until the calibration cycle is concluded and the display returns to normal operation mode. Reenter the calibration mode, then press the **RANGE** button to select the % GAS [%HI] range. Next set the “ZERO GAS” setting for the % Gas [%HI] range while sampling known gas-free air. Step through the Oxygen and Toxic zero settings (it is not necessary to make any adjustments to these settings) to the “Span Gas” mode for the % Gas [%HI] range. Apply a known concentration of methane (usually 50%) and adjust the reading to the appropriate value. Then press **ADJUST/ENTER** to sequence through the remaining span settings and return to the normal operating mode. It is not necessary to repeat adjustments of oxygen or toxic gas zero or span settings during calibration of the % Gas [%HI] range.

Pump

The Land Surveyor uses a pump capable of drawing a sample from a source that is at a vacuum of up to 60” of water column. If pump replacement is required, the pump listed in the Parts List below must be specified.

Parts List

See Parts List in Appendix A for a more complete list of replacement parts and accessories.

Replacement Parts

30-0042-01	Pump, Land Surveyor
61-0124	Sensor, Thermal Conductivity
81-0123	Gas Cylinder, 50% methane/40% carbon dioxide/10% nitrogen (% gas range)
81-1001	Dispensing valve, gas cylinder

GT Transformer Gas Tester

Overview

The GT Transformer Gas Tester is factory configured to monitor for total combustibles from the gas space of power transformers. If transformer faults, such as overheating, hot spots, arcing or corona occur, various combustible gases are generated. If left unchecked, gas can accumulate creating a potential for explosion, failure of the transformer, significant remediation costs and loss of electrical service.

The GT Transformer Gas Tester is designed as an inspection tool to determine if unacceptable levels of gas exist within the transformer. A sample of gas is extracted from the headspace of the transformer by the GT Transformer Gas Tester with a 1:1 dilution fitting in place. If gas levels exceed acceptable levels, additional inspection, including performing a dissolved gas analysis, is required to determine fault condition and appropriate action. If oxygen detection is required, an optional oxygen range can be provided.

Detection Range

The GT Transformer Gas Tester has two detection ranges: 0-100% LEL and 0-5,000 ppm combustibles. An optional range of 0-10,000 ppm combustible and 0-30% oxygen can be provided if requested.

The GT Transformer Gas Tester is calibrated with 2% hydrogen (50% LEL) in the LEL range.

Alarm Points

The alarm points for the combustibles (LEL) range are preset at 10% LEL (WARN) and 50% LEL (ALARM). PPM combustibles alarms are set at 100 and 500 ppm. All alarms are completely user adjustable if alternate alarm points are required. Refer to Appendix B, Channel Setup, for alarm adjustment instructions.

The GT Transformer Gas Tester can also be provided with an optional oxygen channel. The oxygen channel has two user adjustable alarms, one that activates at 19.5% decreasing oxygen and one that activates at 23.5% increasing oxygen.

Dilution Fitting

The GT Transformer Gas Tester includes a dilution fitting to provide the necessary dilution ratio to mix one part sample with one part air.

Description

The catalytic detection method requires oxygen in order to function properly. In an inert gas environment, it is necessary to provide oxygen by the use of a dilution attachment on the inlet fitting to oxidize the combustible gas.

The dilution fitting consists of a small tee fitting which plugs into the inlet fitting of the instrument. It includes two small drilled orifices. One orifice connects to the sample source and the other to atmospheric air. These are proportioned to give a dilution of one part air to one part of sample.

If testing for combustible gas in an inert environment is attempted without the dilution fitting, the GT will respond briefly as the available oxygen is exhausted in the flow block and the combustible readings will then return to zero, providing an incorrect reading.

For testing oxygen content in transformers, the dilution fitting can be removed. This will allow you to determine if there is oxygen present. This test however, can only be performed with the GT Transformer Gas Tester with an active oxygen channel.

GT Transformer Gas Tester Operation Instructions

Before operating the **Thermo** GasTech GT Transformer Gas Tester, it is important that you read and understand the GT Series Operators Manual. It is also extremely important that you are familiar with the specific transformer that you are testing and know how to safely extract a gas sample.

- Turn on the GT Transformer Gas Tester and allow the instrument to warm up.
- Perform fresh air adjustment as described in Chapter 3, Start Up.
- Connect the probe directly to the end of the GT Transformer Gas Tester.
- Open the valve on the Tedlar bag by turning the top of the valve counter clockwise two full turns.
- Connect the tubing from the Tedlar bag to the end of the probe allowing the internal pump to draw the air out of the gas collection bag. When the GT alarms and indicates “Pump off, Press Reset”, turn the valve clockwise until it is completely closed, then remove the tubing from the end of the probe.
- Press the RESET button to restart pump.

- Remove the probe and attach the dilution fitting directly to the inlet fitting of the GT
- Transformer Gas Tester.
- Attach the probe to the dilution fitting.
- Attach the Tedlar bag tubing to the gas sample port of the transformer.
- Open the valve on the bag two full turns then fill the bag with gas from the head space of the transformer, closing the valve when the bag is full.
- Remove the gas collection bag from the transformer.
- Open the valve on the collection bag and attach the bag directly to the inlet of the probe on the GT Transformer Gas Tester.
- View the GT Transformer Gas Tester display to determine the concentration of combustible gas in the transformer.
- Remove the gas collection bag from the probe when complete and close valve on bag.



NOTE

When testing for oxygen content, either remove the dilution fitting from the GT Transformer Gas Tester or place your finger over the small orifice on the dilution fitting before performing test.
